

Exam.	Back		
Level	BE	Full Marks	80
Programme	BEX, BCT, BEL	Pass Marks	32
Year / Part	II / I	Time	3 hrs.

Subject: - Electronic Devices and Circuits (EX501)

- ✓ Candidates are required to give their answers in their own words as far as practicable.
- ✓ Attempt All questions.
- ✓ The figures in the margin indicate Full Marks.
- ✓ Assume suitable data if necessary.

1. Derive the expression for dynamic resistance of pn junction diode. [5]
2. Determine the current I_D and the diode voltage V_D with $V_{DD}=5$ V and $R=1$ K Ω . Assume that the diode has a current of 1 mA at a voltage of 0.7 V and that its voltage drop changes by 0.1 V for every decade change in current. [5]

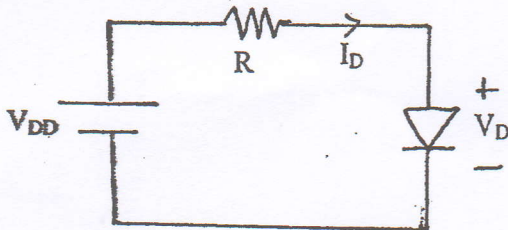

3. Design voltage divider biased common emitter BJT amplifier to get voltage gain of -90. Assume $\beta=100$ and $V_{CC}=+12$ V. [8]
4. Derive input impedance, output impedance and voltage gain of common collector BJT amplifier. [8]
5. Explain the construction and operation of E-MOSFET with characteristics curve and mathematical expression. [7]
6. Derive mathematical definition of JFET transconductance. [4]
7. Find I_{DQ} and V_{DSQ} from the following circuit. Show Q point graphically. [5+3]

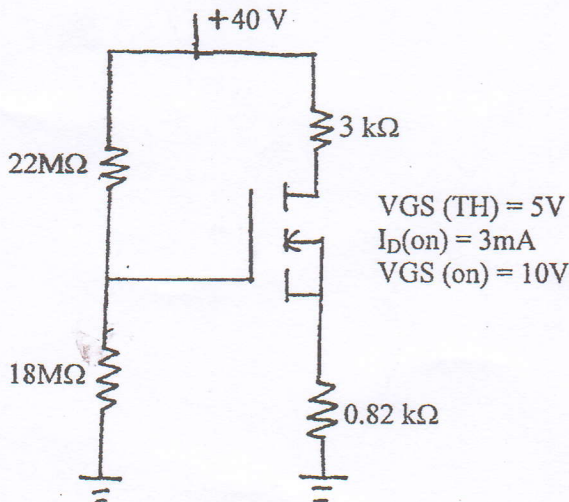

8. Derive general efficiency of class B amplifier. [5]
9. Draw the circuit diagram of Darlington complementary-symmetry class AB amplifier using diodes. [3]
10. Derive maximum efficiency of transformer coupled class A amplifier. [5]
11. Draw astable multivibrator circuit using IC 555 and derive expression for frequency of oscillation. [6]
12. Explain working principle of RC phase shift oscillator with necessary expressions and circuit diagram. [6]
13. Explain the operation of voltage regulator using band gap voltage reference. [6]
14. Design a (5-15)V variable dc voltage regulator using LM 317 IC. [4]

Exam.	Regular		
Level	BE	Full Marks	80
Programme	BEL, BEX, BCT	Pass Marks	32
Year / Part	II / I	Time	3 hrs.

Subject: - Electronic Devices and Circuits (EX501)

- ✓ Candidates are required to give their answers in their own words as far as practicable.
- ✓ Attempt All questions.
- ✓ The figures in the margin indicate Full Marks.
- ✓ Assume suitable data if necessary.

- The leakage current of a silicon diode is $I_S = 10^{-9}$ A at 25°C , and the emission coefficient is $\eta = 1.6$. The operating junction temperature is $T_j = 60^\circ\text{C}$. Determine (i) the leakage current I_S and (ii) the diode current I_D at $V_D = 0.8$ V. [4]
- The 6.8V zener diode is specified to have $V_Z = 6.8$ V at $I_Z = 5$ mA, $r_z = 20 \Omega$ and $I_{zk} = 0.2$ mA. The supply Voltage V^+ is nominally 10 V but can vary by ± 1 V. Find V_0 with no load and with V^+ at its nominal value. Find the change in V_0 resulting from connecting a load resistance R_L that draws a current $I_L = 1$ mA. What is the minimum value of R_L for which the diode still operates in the breakdown region? [2+2+2]

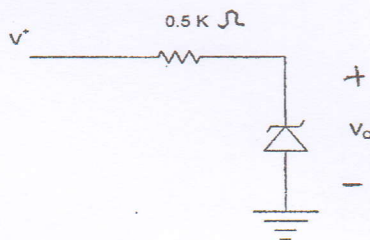

- Determine the input resistance, output resistance and overall voltage gain of the circuit given below: [8]

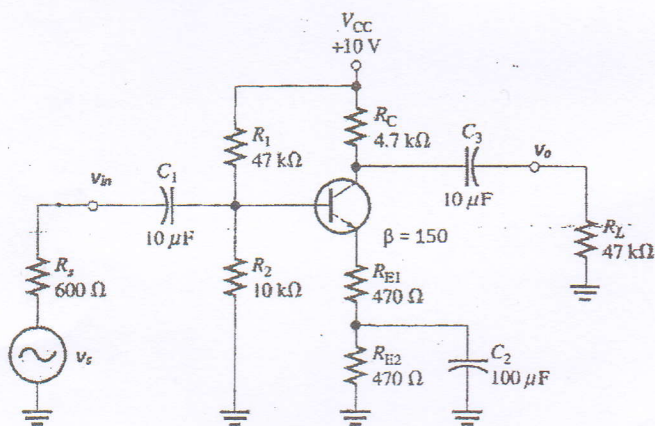

- Find terminal currents of BJT using Ebers-Moll Model. Write applications of different BJT configurations. [5+3]
- Explain the construction and operation of D-MOSFET with characteristics curve and mathematical expression. [8]

6. Find the DC operating point of JFET circuit given below. Given parameters $I_{DSS} = 12 \text{ mA}$ and $V_P = -4\text{V}$. [8]

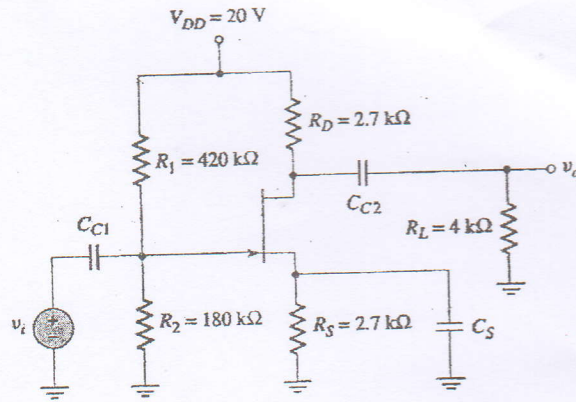

7. Derive maximum efficiency of series fed class A amplifier. [6]
8. Derive bandwidth of tuned amplifier. Write its applications. [6]
9. For a class B amplifier providing a 14V peak signal to 16Ω load and a power supply of $V_{cc} = 24\text{V}$, determine input power, output power and circuit efficiency. [4]
10. Draw voltage controlled oscillator circuit using IC 555 and derive expression for frequency of oscillation. [6]
11. Draw the circuit diagram of half wave precision rectifier and explain the operation. [4]
12. Define voltage regulator. Explain the series voltage regulator with current limiting element. [1+5]
13. Explain working principle of WIEN BRIDGE oscillator with necessary expressions and circuit diagram. [6]

Exam.	Back		
Level	BE	Full Marks	80
Programme	BEL, BEX, BCT	Pass Marks	32
Year / Part	II / I	Time	3 hrs.

Subject: - Electronic Device and Circuits (EX501)

- ✓ Candidates are required to give their answers in their own words as far as practicable.
- ✓ Attempt All questions.
- ✓ The figures in the margin indicate Full Marks.
- ✓ Scientific Calculator is allowed.
- ✓ Assume suitable data if necessary.

1. Explain the small signal model of PN junction diode and drive its dynamic resistance. [2+4]
2. Determine the range of values of V_i that will maintain the Zener diode of figure below in ON state. [5]

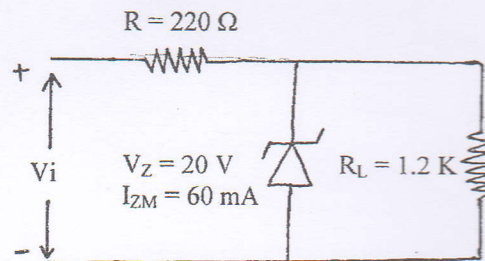

3. Design β independent type DC biased common emitter amplifier with emitter resistance bypassed and find its voltage gain and input resistance. Given parameters $V_{cc} = 24$, $I_C = 2$ mA, $\beta = 90$. Use appropriate guideline to have high input resistance. [8]
4. Describe in brief the operation of BJT as a switch in cut off and saturation region. [6]
5. Define transconductance (g_m). Derive g_m for BJT. [1+3]
6. Explain the construction and operation of N channel enhancement type MOSFET with the help of drain characteristics and transfer characteristics. [8]
7. Find the drain current (I_D) and drain to source voltage (V_{DS}) for the following circuit. Given parameters are: $V_t = 1$ V and $k = 0.5$ mA/V². [6]

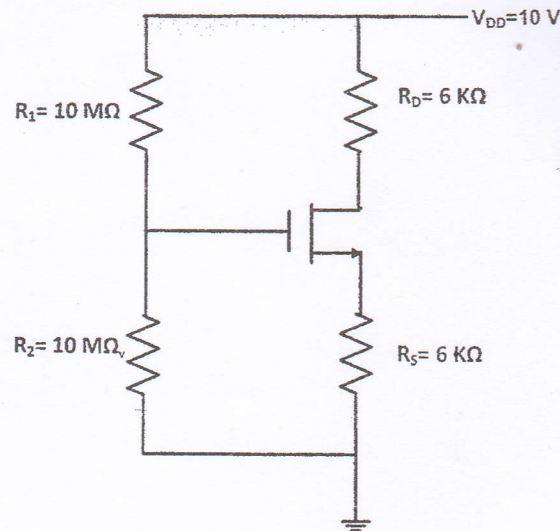

8. State the difference between BJT and FET. [2]
9. What is crossover distortion? Explain how it can be eliminated with necessary diagram. [2+4]
10. Draw the circuit diagram of tuned amplifier and derive the expression for the 3dB bandwidth of the amplifier. [6]
11. Define Barkhausen criteria for sinusoidal oscillation. Draw the circuit diagram of wien bridge oscillator and determine its frequency of oscillation. [2+6]
12. Describe Colpitt's oscillator with necessary circuit diagram. [5]
13. Draw the standard series DC voltage regulator circuit and find its voltage stability factor (S_V). [6]
14. Design a 3.7 to 9V variable dc voltage regulator using IC LM317. [4]

Exam.	New Back (2066 & Later Batch)		
Level	BE	Full Marks	80
Programme	BEL, BEX, BCT	Pass Marks	32
Year / Part	II / I	Time	3 hrs.

Subject: - Electronic Devices and Circuits (EX501)

- ✓ Candidates are required to give their answers in their own words as far as practicable.
- ✓ Attempt All questions.
- ✓ The figures in the margin indicate Full Marks.
- ✓ Assume suitable data if necessary.

1. Find operating point for the diode circuit graphically using load line method. [4]
2. Find the zener current from the given circuit if (i) $R_L = 1.2 \text{ K } \Omega$ (ii) $R_L = 3 \text{ K } \Omega$ [4]

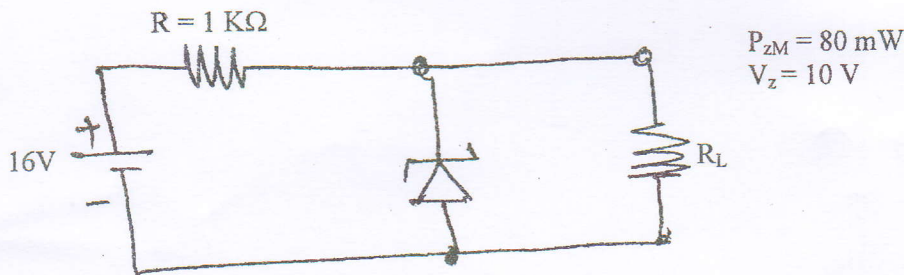

3. Determine the input resistance and output resistance of CC BJT amplifier circuit. Why common collector configuration is used in amplifier circuit design. [2+2+2+2]
4. Describe the operation of BJT as switch with the help of Non-gate circuit. [4]
5. Derive expressions to obtain transconductance for BJT, JFET and MOSFET. Also prove that $\gamma_\pi = (\beta + 1)\gamma_e$. [8]
6. The n-channel JFET in the figure below has $I_{DSS} = 18 \text{ mA}$ and $V_p = -5\text{V}$. Determine the values of I_D and V_{DS} . [8]

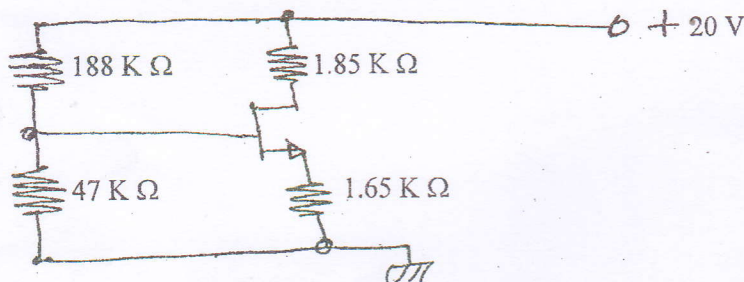

7. Describe the working principle of N-channel EMOSFET with the help of its drain characteristics curve and necessary mathematical expressions. [6]

8. Determine the general efficiency of transformer coupled class B push pull amplifier. Draw the circuit diagram and its graph. [4+4]
9. Explain how class AB amplifier eliminates the cross over distortion. [3]
10. Draw the circuit diagram of LRC tuned class A amplifier and its frequency response graph and show that $\text{Bandwidth} = \frac{1}{RC}$. [3+3]
11. Explain the operation of AMV using 555 timer IC and derive its frequency of oscillation. [6]
12. Draw the circuit diagram of Hartley oscillator. [3]
13. Draw standard dcV regulator circuit and find its voltage stability factor. [4+4]
14. Design a DCV regulator for 3.7 V to 12 V output using LM317. [4]

Exam.	Regular		
Level	BE	Full Marks	80
Programme	BEL, BEX, BCT	Pass Marks	32
Year / Part	II / I	Time	3 hrs.

Subject: - Electronic Devices and Circuits (EX501)

- ✓ Candidates are required to give their answers in their own words as far as practicable.
- ✓ Attempt **All** questions.
- ✓ The figures in the margin indicate **Full Marks**.
- ✓ Assume suitable data if necessary.

1. In the given circuit, the diode used has its $n = 1.74$ and it conducts 1mA at forward bias voltage of 0.7V . Find the current flow in the circuit. [4]

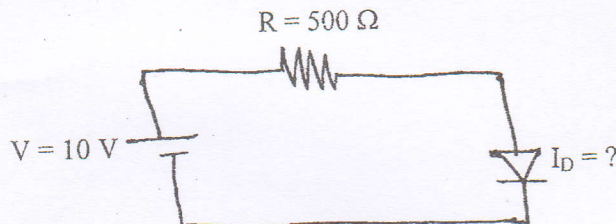

2. Design DC voltage regulator for 6V output. Given data are $V_z = 6\text{V}$ at $I_z = 20\text{mA}$, $I_{2k} = 2\text{mA}$, $P_{Z\text{max}} = 500\text{mw}$ and $r_z = 10\ \Omega$. The nominal input voltage is $15\text{V} \pm 30\%$ DC. Find maximum current it can deliver to the load. [4]
3. Design β independent type dc biased common collector amplifier and find its current gain and input resistance. Given parameters are: $V_{CC} = 20\text{V}$, $I_C = 2\text{mA}$ and $\beta = 100$. Use firm biasing method. [8]
4. Draw the small signal model circuit for capacitor unbypassed CE amplifier and find its voltage gain and current gain. [8]
5. Describe the construction and working principle of N-channel JFET with the help of its drain characteristics curve and necessary mathematical expressions. [6]
6. For the circuit given below, find I_D and V_{DS} . Also determine its region of operation and small signal ac equivalent circuit. [3+3+2+2]

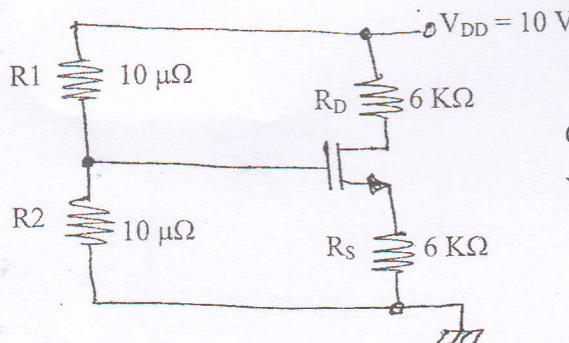

Given data are:

$$V_t = 1\text{V}, k = 0.5 \frac{\text{mA}}{\text{V}^2}$$

7. Draw the circuit diagram of transformer coupled class B push pull amplifier and its corresponding characteristic graph. And from graph prove that maximum efficiency is equal to 78.5%. Also find the condition when it has maximum loss. [3+3+3+3]
8. Draw the circuit diagram and its frequency response graph of LRC tuned class A amplifier. State its resonance frequency and band width (3dB). [1+1+1+1]
9. State Barkhausen criteria for sinusoidal oscillator. Is this principle applicable to RC oscillator using op-Amp? Why? If yes, determine the frequency of oscillations and the gain of the amplifier of the circuit. [2+1+4]
10. Explain the operation of AMV using 555 IC and derive its frequency of oscillation. [6]
11. Describe the bandgap voltage reference source with the help of a relevant circuit. Compare bandgap voltage reference source with zener diode. [4+2]
12. Draw the series dc voltage regulator with current limiting element and explain how it works. 7 [5]

Exam.	Regular		
Level	BE	Full Marks	80
Programme	BEL, BEX, BCT	Pass Marks	32
Year / Part	II / I	Time	3 hrs.

Subject: - Electronic Device and Circuits (EX501)

- ✓ Candidates are required to give their answers in their own words as far as practicable.
- ✓ Attempt All questions.
- ✓ The figures in the margin indicate Full Marks.
- ✓ Assume suitable data if necessary.

1. Draw full wave bridge rectifier circuit with 5 ohm load resistor connected at its output. If input ac voltage is 10V, calculate the power dissipation in the load resistor (Assume diodes operate at forward voltage of 0.7V). [4]
2. Explain the small signal model of PN junction diode and derive the expression for AC or dynamic resistance. [2+4]
3. Draw the ac equivalent circuit for given circuit and find its input and output resistances. Assume $\beta = 100$ for the BJT. [8]

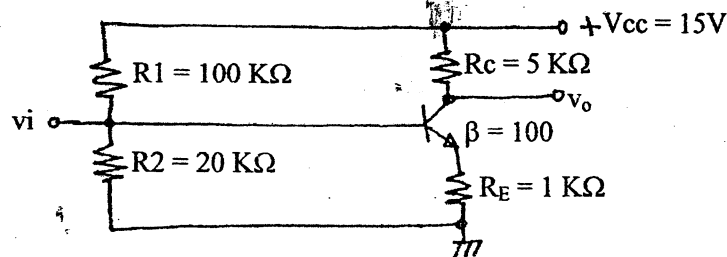

4. Define transconductance (g_m). Derive g_m for BJT. [2+4]
5. Describe in brief the operation of BJT as a switch. [4]
6. Describe with necessary graphs and expressions the principle of operation of N-channel JFET. [6]
7. The n-channel JFET in the figure below has $I_{DSS} = 18 \text{ mA}$ and $V_P = -5\text{V}$. Determine the values of I_D and V_{DS} . [8]

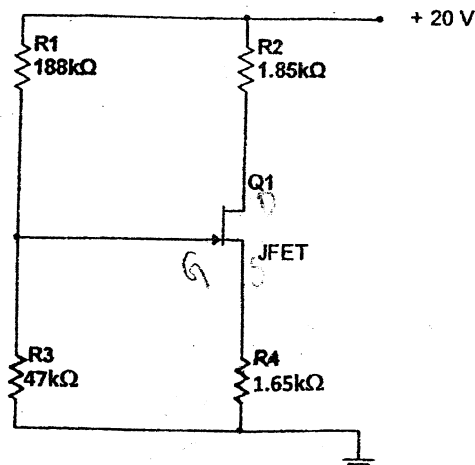

8. State the difference between BJT and FET. [4]
9. Determine the general efficiency of Transformer Coupled Class-A power Amplifier. [6]
10. Draw the circuit diagram of Complementary-Symmetry Class-AB Amplifier. [2]
11. Calculate the efficiency of transformer coupled push pull Power Amplifier for a supply voltage of 20V and output of (i) $V_p = 20V$ (ii) $V_p = 16V$. [3+3]
12. Draw Wien Bridge Oscillator circuit and derive the expression for frequency of Oscillation and gain of the amplifier circuit. [2+3+3]
13. Draw standard series dc voltage regulator and find its voltage stability factor (S_v). [6]
14. Design a 4.2 V to 12 V variable dc voltage regulator using IC LM317. [4]
15. Draw the circuit diagram of square wave generator. [2]

Exam.	Regular		
Level	BE	Full Marks	80
Programme	BEL, BEX, BCT	Pass Marks	32
Year / Part	II / I	Time	3 hrs.

Subject: - Electronic Devices and Circuit (Ex 501)

- ✓ Candidates are required to give their answers in their own words as far as practicable.
- ✓ Attempt All questions.
- ✓ The figures in the margin indicate Full Marks.
- ✓ Assume suitable data if necessary.

1. Explain the large signal models of PN junction diode. [4]
2. A diode conducts 1mA at 20°C. If it is operated at 100°C, what will be its current? Given data are: $\eta=1.8$ and negative temperature coefficient value = $-1.8\text{mv}/^\circ\text{C}$. [4]
3. For the figure shown below with $\beta = 120$ find the a) input impedance (b) Output impedance (c) voltage gain (d) current gain. Use small signal model. [2+2+2+2]

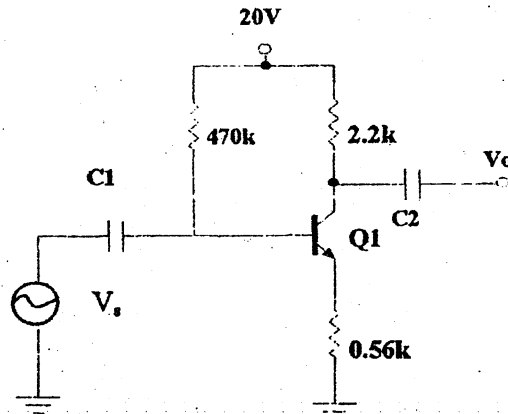

4. Draw ac equivalent circuit of common collector amplifier. Find its input and output resistances. [2+3+3]
5. Describe the physical structural of N-channel JEET and explain its working principle and characteristics clearly marking the various regions of operation. [2+6]
6. Derive the expression to obtain the transconductance of E-MOSFET. [4]
7. Find the drain current (I_D) and drain to source voltage (V_{DS}) for the following circuit. Given parameters are: $V_t = 1\text{V}$ and $k = 0.5\text{mA}/\text{V}^2$. [4]

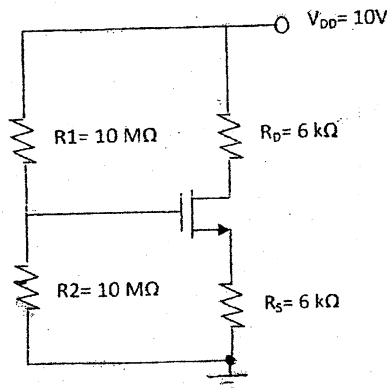

8. Draw the circuit diagram of class B push pull amplifier with output transformer and explain how push pull action is achieved. Determine the general efficiency of class B push pull amplifier. [1+3+4]
9. Draw class A tuned amplifier circuit and derive the expression for 3dB bandwidth of the amplifier. [2+6]
10. Describe the operation of IC 555 as square wave oscillator and find its frequency of oscillation. [6+2]
11. Estimate voltage stability factor (S_V) for standard series dc voltage regulator using BJT. Also, explain the operation of overload protection circuit that could be used in series voltage regulator circuit. [5+3]
12. A class B audio amplifier is providing 20V peak sine wave signal to 8Ω speaker with power supply of 25V ($=V_{CC}$). At what efficiency is it operating? [4]
13. Define and explain the reverse breakdown effect in diodes. [4]

Exam.	Regular / Back		
	Level	BE	Full Marks
Programme	BEL, BEX, BCT	Pass Marks	32
Year / Part	II / I	Time	3 hrs.

Subject: - Electronic Devices and Circuits

- ✓ Candidates are required to give their answers in their own words as far as practicable.
- ✓ Attempt All questions.
- ✓ The figures in the margin indicate Full Marks.
- ✓ Assume suitable data if necessary.

1. Draw graphs of IV characteristics of ordinary PN junction diode and zener diode. Draw ac equivalent model for PN junction diode and derive its ac resistance. [7]
2. Define and explain reverse break down effect. [3]
3. Design β -independent type dc biased common collector amplifier, and find its current gain and input resistance. Given parameters are: $V_{CC} = 20V$, $I_C = 2mA$, $\beta = 100$ and use firm biasing method. [8]
4. Derive an expression to find output resistance for emitter unbypassed common emitter amplifier circuit. [5]
5. Draw Ebers Moll model and ac equivalent T- model for BJT. [4]
6. Describe the principle of operation of EMOSFET with the help of IV characteristic curves and algebraic expressions. Also show its ac equivalent circuit model. [7]
7. Find I_D and V_{DS} for the given circuit. [5]

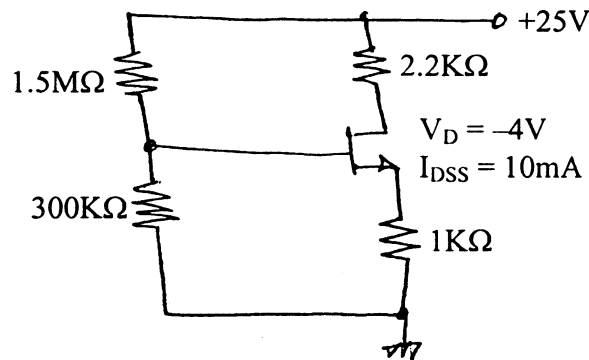

8. Derive an expression to find the transconductance for JFET. [2]
9. Draw standard series dc voltage regulator circuit and find its voltage stability factor (S_v). [6]
10. Draw a voltage regulator circuit using IC LM317. [3]
11. Draw a circuit diagram for Bandgap reference voltage source. [3]
12. Define cross over distortion in class B amplifier. Draw quasi-complementary symmetry class AB amplifier. And explain how crossover distortion is eliminated in class AB amplifier. [7]
13. What is the maximum efficiency of class B amplifier? State the condition when it occurs. [4]
14. Why heat sink is necessary in power transistor? Explain with the help of thermal Ohm's law or thermal resistance method. [4]
15. State Barkhausen criteria and explain the principle of oscillation. [4]
16. Draw Wien Bridge Oscillator circuit and write the expression for frequency of Oscillation. [6]
17. Draw crystal oscillator circuit. [2]

Exam.	Regular / Back		
Level	BE	Full Marks	80
Programme	BEL, BCT, BCT	Pass Marks	32
Year / Part	II / II	Time	3 hrs.

Subject: - Electronic Circuits I

- ✓ Candidates are required to give their answers in their own words as far as practicable.
 - ✓ Attempt All questions.
 - ✓ The figures in the margin indicate Full Marks.
 - ✓ Assume suitable data if necessary.
- ✓ 1. With the aid of $i_D - v_{GS}$ curve, verify that the transconductance g_m of a MOSFET depends upon the dc bias point. [5]
 - ✓ 2. State why the resistors and capacitors are minimized in IC fabrication. [5]
 3. Explain how the voltage gain of difference amplifier would be larger when a current mirror is used at the load as compared to using only a simple resistance at the load. [6]
 4. Draw emitter follower with voltage divider and current mirror dc level shifting circuits and which circuit performs better results and why? [2+2+3]
 - ✓ 5. Find the close loop input impedance of non inverting Op-amp. Derive the expression to reduce the effect of input offset current in an Op-amp. [4+3]
 - ✓ 6. For a non- inverting op-amp $R_i = 1K\Omega$, $R_f = 20 K\Omega$, $V_{CC} = \pm 15$ volt. The op-amp has a slew rate of $0.5V/\mu\text{sec}$, and a saturation dropout voltage of 10%. Find maximum input voltage in RMS value at 10 KHz sine wave. [6]
 - ✓ 7. Draw circuit diagram of variable series voltage regulator with transistor error amplifier circuit and derive its voltage regulation factor, S_v . [2+5]
 8. Design a regulator circuit diagram to obtain 16 VDC with input voltage of 25 VDC. [5]
 9. Draw a circuit diagram of transformer coupled class B push pull amplifier clearly. And determine its maximum efficiency. [3+5]
 - ✓ 10. Discuss crossover distortion in push pull amplifier, and state how you can eliminate it. [6]
 11. Define Barkhausen Criteria for sinusoidal oscillation. Draw a circuit diagram of RC oscillator and derive its frequency of oscillation. [3+1+8]
 - ✓ 12. Draw the circuit diagram of triangular wave generator. Explain the operation of square wave generator circuit. [2+4]

Examination Control Division

2067 Shrawan

Exam.	Back		
Level	BE	Full Marks	80
Programme	BEL, BEX, BCT	Pass Marks	32
Year / Part	II / II	Time	3 hrs.

Subject: - Electronic Circuits I

- ✓ Candidates are required to give their answers in their own words as far as practicable.
- ✓ Attempt **All** questions.
- ✓ The figures in the margin indicate **Full Marks**.
- ✓ Assume suitable data if necessary.

1. List out the advantages of monolithic IC as compared with discrete components. 4
2. Draw hybrid- π model of BJT as a) voltage controlled current source, b) current controlled current source. 3+3=6
3. Draw a simple current mirror and describe its operation. What are the reasons for the output current of a simple current mirror not being exactly equal to the reference current? 2+4+4=10
4. Discuss the importance of active load and level shifting circuit in op-amps. 5+5=10
5. Define slew rate of an op-amp. A 10mV-10 kHz sine wave is input to an op-amp with a gain of 1000. Calculate the minimum slew rate that is required for the op-amp to produce an output without any distortion. (The sine wave and slew rate are related with the expression $SR=2\pi fA$) 3+4=7
6. For an inverting op amp, $R_i = 1k$, $R_f = 10k$, $V_{cc} = \pm 15V$. The op amp has a slew rate of $0.5V/\mu S$, a saturation dropout voltage of 10% and gain bandwidth product of 1 MHz. Plot the gain and phase response of the circuit, and also show the output waveform when a 5V peak to peak sine wave of 1 kHz frequency is used as the input to this circuit. 2+2+2=6
7. Define loading effect in unregulated power supply. Draw a series transistor zener diode voltage regulator, and state how this problem is taken care of by this circuit. 2+6=8
8. Compare zener diode with bandgap voltage reference. 4
9. How does cross over distortion occur in class B push pull amplifier? Discuss the change in effects of cross over distortion when the magnitude of the input signal is reduced, and when the frequency is decreased. What will you do to eliminate cross-over distortion? Discuss the impact of this remedy in terms of power dissipation. 3+2+2+3+2=12
10. Describe "Barkhausen Criteria" for oscillation. Write down the general expression for the gain of a feedback amplifier, and state the condition for oscillation. 5
11. Draw and explain the operation of CMOS inverter relaxation oscillator. 8
